



Gate valve PN16/25

901/02

Metal sealed, non-rising stem gate valve to BS EN 1171
Face to face dimension to BS EN 558-1, series 3 (PN16), series 4/19 (PN25)
Flanges and drilling to BS EN 1092-2

Use:

For water to max. 90°C

Test:

Hydraulic test to BS EN 12266

Seat: 1.1 x PN

Body: 1.5 x PN

Operating torque test

Optional extras:

Hand wheel, worm gear.

Marking:

To BS EN 1171

Body: ICV logo, DN, PN, casting no.
and body material.

Materials

Seat	Bronze
Disc	Ductile iron
Body	Ductile iron
Gasket	Flexible graphite
Bonnet	Ductile iron
Packing	Flexible graphite+F4
Packing gland	Ductile iron
Stem	Stainless steel
Stem nut	Brass
Hand wheel	Cast iron
Hand wheel nut	Steel



The designs, materials and specifications shown are subject to change without notice due to our continuing programme of product development.

A Member of the AVK Group

DS901021804

Metal sealed, non-rising stem gate valve to BS EN 1171
Face to face dimension to BS EN 558-1, series 3 (PN16), series 4/19 (PN25)
Flanges and drilling to BS EN 1092-2

Component list

- | | | |
|-------------|------------------|--------------------|
| 1. Seat | 6. Bonnet | 11. Hand wheel nut |
| 2. Disc | 7. Packing | |
| 3. Body | 8. Packing gland | |
| 4. Stem nut | 9. Stem | |
| 5. Gasket | 10. Hand wheel | |

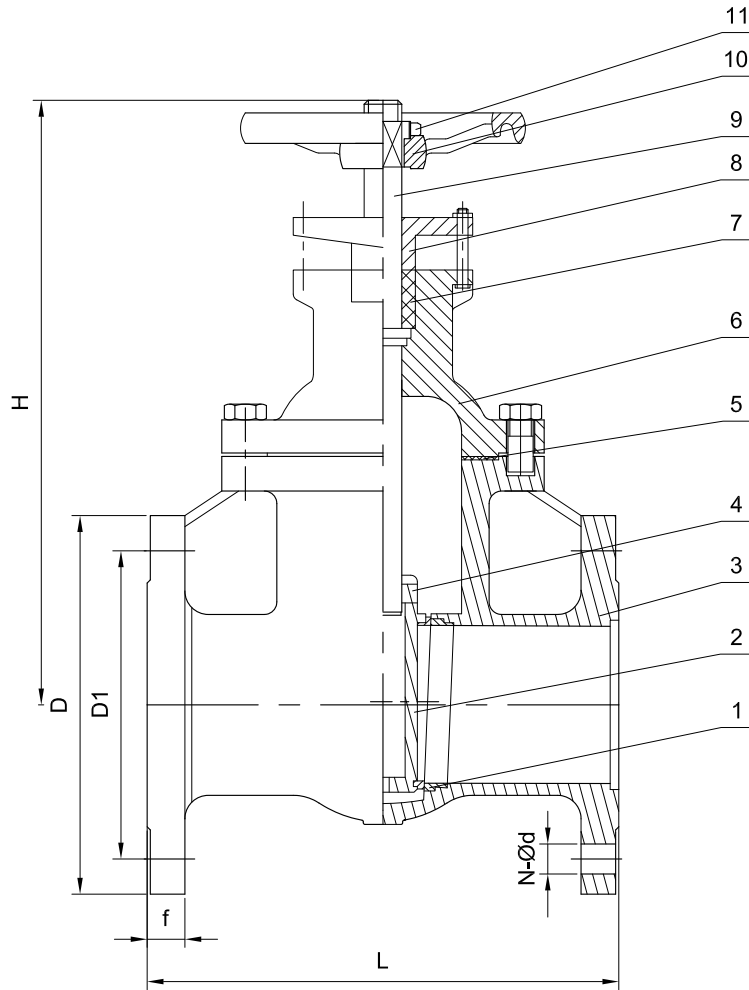

Ref.no.	DN	L		H		D		D1		N-ød		f		Weight	
		mm	mm	mm	mm	mm	mm	mm	mm	mm	mm	mm	mm	PN16	PN25
901020050XY01	50	178	216	276	285	165	165	125	125	4-ø19	4-ø19	20	22	11.5	23
901020065XY01	65	190	241	302	308	185	185	145	145	4-ø19	8-ø19	20	22	14.05	26
901020080XY01	80	203	283	332	356	200	200	160	160	8-ø19	8-ø19	22	22	17.7	44
901020100XY01	100	229	305	384	400	220	235	180	190	8-ø19	8-ø23	24	23	26.35	60
901020125XY01	125	254	381	435	448	250	270	210	220	8-ø19	8-ø28	26	25	39.1	76
901020150XY01	150	267	403	497	520	285	300	240	250	8-ø23	8-ø28	26	26	51.95	98
901020200XY01	200	292	419	608	612	340	360	295	310	12-ø23	12-ø28	30	29	81	130
901020250XY01	250	330	457	721	728	405	425	355	370	12-ø28	12-ø31	32	32	132	190
901020300XY01	300	356	502	838	835	460	485	410	430	12-ø28	16-ø31	32	36	181	270
901020350XY01	350	381	387	975	1550	520	555	470	490	16-ø28	16-ø34	36	39	330	350
901020400XY01	400	406	416	1132	1805	580	620	525	550	16-ø31	16-ø37	38	42	400	415

X=1, PN16 X=3, PN25
 Y=1, Epoxy coating RAL7011 Y=5 Normal paint

