



ICV MANUAL BALANCING VALVES PN25, DN200-400

908/00

Epoxy coated, ductile iron, flanged

002

Manual balancing valves deliver accurate hydraulic performance in an impressive range of applications, offer a reliable, simple and cost effective way to measure and balance all flow rates. The valve is ideal for use mainly on the secondary side in heating and cooling systems.

Product Description:

Manual Balancing Valve for water and water with glycol from -10°C to 110°C

Standards:

- Face to face according to EN 558 Table 2 Basic Series 1
- Standard flange drilling to EN1092 (ISO 7005-2), PN 25

Test/Approvals:

- Test according to EN 12266-1 and EN 12266-2

Features:

- Flange connection
- Measuring ports for measuring differential pressure
- Handwheel with turn counter for easy reading and adjustment
- Equal percentage control of flow
- Soft seat offers tight shut-off
- Locking device/max opening device integrated in stem
- Feet on flanges for easier transport
- External surface fusion bonded epoxy coated (Grey RAL7011)
- Change of seal house O-ring during use possible at fully open valve position (back seating)

Accessories:

Allen key for locking device (one key is included)

2" P/T port

4" P/T port

P/T with drain

Options:

Balancing tool



Selecting and setting diagram (example shown)

Wanted:

Presetting for DN250 at a desired flow rate of 250 m³/h and a pressure drop of 20 kPa.

Solution:

Draw a straight line joining 250 m³/h and 20 kPa. This gives Kv=560

Now draw a horizontal line from Kv=560

This intersects the bar for DN250 at the desired presetting of 7.4 turns.

Remark:

DN200 at a presetting of 11.8 turns and DN300 at a presetting of 7.3 turns would also be suitable.

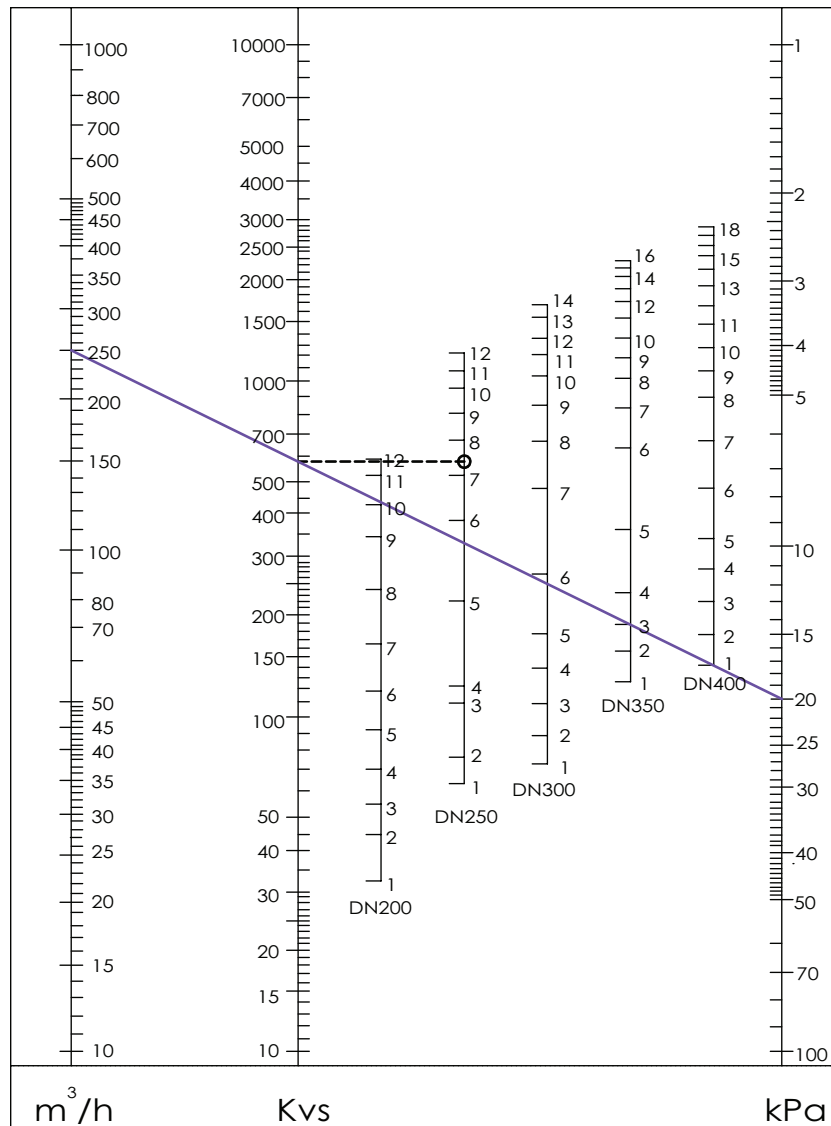

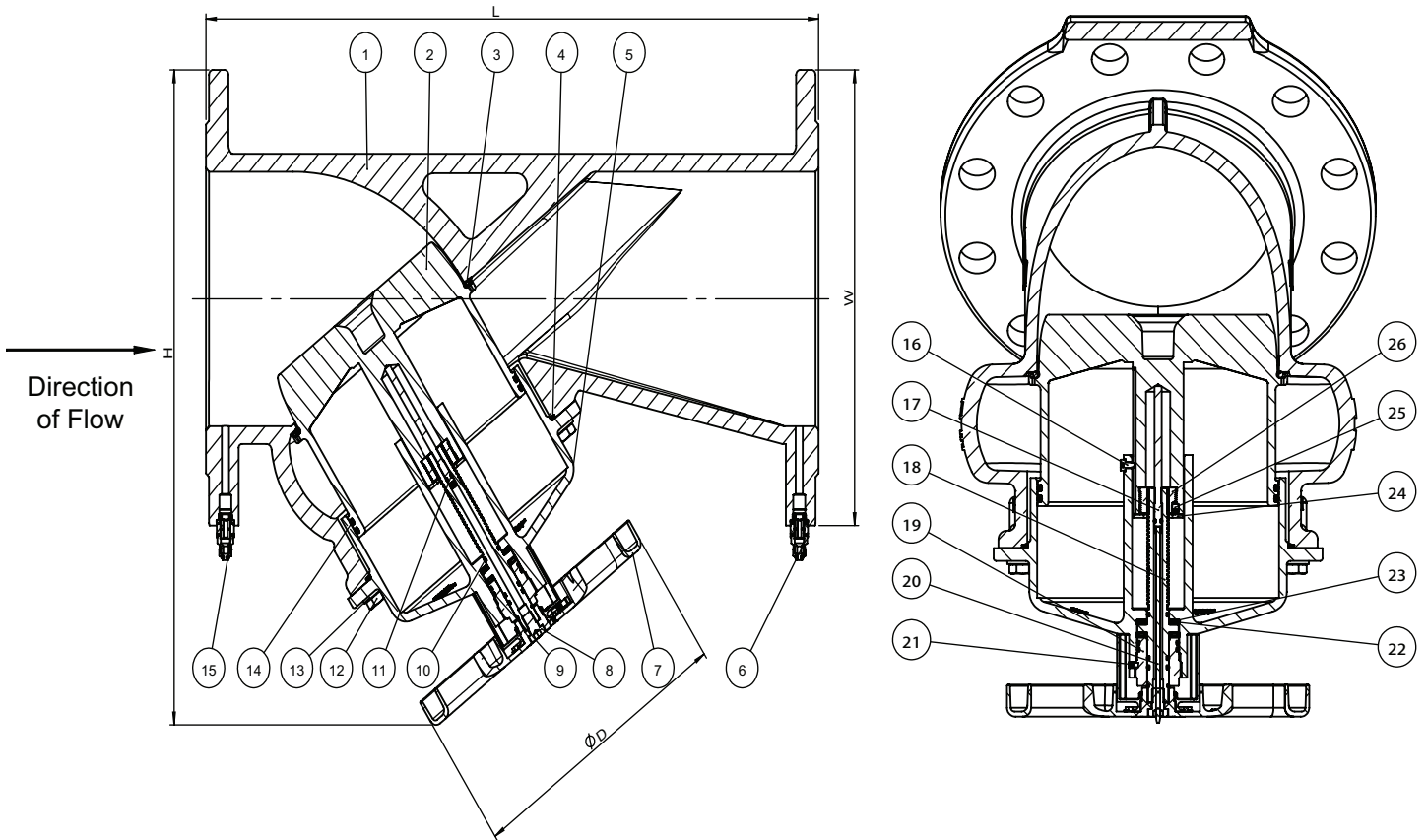

Component List:

1. Body	Ductile iron, GJS-500-7	2. Plug	DI GJS-500-7 Corrosion protected
3. O-ring	NBR rubber	4. O-ring	NBR rubber
5. Bonnet	Ductile iron, GJS-500-7	6. Measuring port (Blue)	Brass
7. Handwheel	Aluminum alloy	8. Handwheel screw	Stainless steel Grade A2
9. O-ring	NBR rubber	10. O-ring	NBR rubber
11. O-ring	NBR rubber	12. Bolt	Grade 8.8 Zinc
13. Washer	Grade 8.8 Zinc	14. O-ring	NBR rubber
15. Measuring port (Red)	Brass	16. Grub screw	Steel ST.45H
17. Locking device	Stainless steel 1.4021	18. Stem	Stainless steel 1.4021
19. Seal house	Brass, HPb 59-1	20. Special allen key	Steel
21. Set screw	Stainless steel Grade A4	22. Axial bearing	Steel ST.12
23. Axial bearing washer	65 Mn	24. Gasket	NBR rubber
25. Plug screw	Stainless steel Grade A4	26. Stem nut	Brass, HPb 59-1

Components may be substituted with equivalent or higher class materials without prior notification.

Reference Nos. and Dimensions:

AVK ref. nos	DN mm	Flange drilling	L mm	D mm	H mm	W mm	Kvs* m³/h	Theoretical weight kg
908-0200-00-736	200	25	600	250	516	360	572	64
908-0250-00-736	250	25	730	250	649	425	1214	134.5
908-0300-00-736	300	25	850	250	717	485	1673	191
908-0350-00-736	350	25	980	250	783	555	2251	302.5
908-0400-00-736	400	25	1100	250	880	620	2882	408.5

* Fully open position m³/h @ 1 bar differential pressure

Turns	Kv [m3/h]				
	DN200	DN250	DN300	DN350	DN400
0.0	0	0	0	0	0
0.5	14	26	29	50	56
1.0	35	65	72	126	141
1.5	39	70	78	138	155
2.0	45	76	87	156	177
2.5	49	90	96	170	194
3.0	55	110	109	190	221
3.5	61	115	121	208	243
4.0	70	122	140	236	277
4.5	79	161	155	289	302
5.0	92	221	177	369	341
5.5	102	285	212	474	395
6.0	118	383	263	632	476
6.5	137	440	351	715	558
7.0	165	525	483	839	681
7.5	203	597	582	928	788
8.0	240	669	681	1017	896
8.5	295	741	772	1103	991
9.0	349	812	863	1190	1087
9.5	390	881	947	1281	1181
10.0	430	950	1032	1372	1275
10.5	476	1013	1118	1452	1381
11.0	521	1077	1204	1533	1486
11.5	547	1146	1287	1623	1586
12.0	572	1214	1369	1713	1687
12.5			1451	1799	1799
13.0			1533	1886	1911
13.5			1603	1966	2025
14.0			1673	2046	2139
14.5				2102	2242
15.0				2157	2344
15.5				2204	2435
16.0				2251	2526
16.5					2618
17.0					2709
17.5					2796
18.0					2882

Accuracy:
 ± 5% at full open valve
 ± 10% (according to BS 7350:1990) in normal operating range (outside shaded area)